



Full Length Research Article

AUTOMATIC HUMIDITY MONITORING AND PUMPING SYSTEM FOR FARMERS

***Manish Sharma, Mamta Kumara and Vikas Kumar**

Department of Electrical Engineering, BK Birla Institute of Engineering and Technology, Pilani, Rajasthan, India

ARTICLE INFO

Article History:

Received 22nd January, 2016
Received in revised form
19th February, 2016
Accepted 24th March, 2016
Published online 27th April, 2016

Key Words:

Soil moisture sensor,
Temperature sensor SHT15,
Humidity sensor,
Water level sensor,
IC NE555, Drip, Crop,
Automatic sprinkling system,
Submersible motor,
Water pumping system.

ABSTRACT

The main aim of Automatic Humidity Monitoring and Pumping System for Farmers project is to monitor and record values of humidity of natural environment and to pump the plants water at required humidity level in order to achieve maximum plant growth and yield. This paper main intention is to develop a application where it can collect data about soil conditions with a low cost equipment and less labour involved. It can also possible with the help of a drip irrigation system, through solar power, using vocal commands through the mobile phone and wireless sensor network. This paper also consist wireless sensor network for real time data sensing and control of an irrigation system. This paper also combine the water saving irrigation system is automatic control through the GSM (global system for mobile communication). This paper introduces an automatic module to supply appropriate amount of water to the field by sensing the crop humidity requirement also. It even reduces probability of soil erosion and protects the crop rotting due to over irrigation during heavy rainfall with advanced rainfall unit. This system will be economical in terms of hardware cost and power consumption. It also introduces a humidity sensor and temperature sensor at field where sprinkling has to be done with respect to the quantity of water needed. The circuit monitors the water level of the tank, to prevent dry run and damage to pump. The main purpose of this project is to automate the data acquisition process of the soil conditions and various climatic parameters that govern plant growth allows information to be collected at high frequency with less labour requirements. In this project the design is simple and easy to install. An integrated Liquid crystal display (LCD) is also used for real time display of data acquired from the sensor and the sensor and the status of the device. The design is quite flexible as the software can be changed any time.

Copyright © 2016, Manish Sharma et al. This is an open access article distributed under the Creative Commons Attribution License, which permits unrestricted use, distribution, and reproduction in any medium, provided the original work is properly cited.

INTRODUCTION

During present days the agriculture fields are decreasing day by day due to scarcity of an electricity and water. The world is facing a another problem that is a population .Now a days the population is increasing day by day then there needs a lot a food crops to satisfied the today population. There is a need of a new technology in a agricultural system that is automatic humidity monitoring and pumping system for farmers. By using this technique irrigation water management practices could greatly benefit by the knowledge of moisture in the soil. To determine the soil moisture we have designed and developed a nickel probes based soil moisture sensor and a response monitoring system. By knowing the moisture value, we can estimate when to water and how much to water the fields so that there is no over- watering or wilting of crops.

***Corresponding author: Manish Sharma,**
Department of Electrical Engineering, BK Birla Institute of Engineering and Technology, Pilani, Rajasthan, India.

These practices will increase crop yield, improve quality of crops, conserve water resources, save energy, and decrease fertilizer supplies. Another technique is automatic irrigation system through a solar power. By using this technique it can produce a crop in a efficient ways and the farmer has no need to continuously monitor the soil and weather conditions in favour of growth of crops. In this project mainly the solar power is used to supply required power to the pump set and the humidity sensors are used to sense whether the soil is in a wet or dry conditions. An intelligent drip irrigation system optimizes water and fertilizer use for agricultural crops using wireless sensors and fuzzy logic. The wireless sensor networks consists of many sensor nodes, hub and control unit. The sensor collects real-time data such as temperature, soil humidity. This data is sent to the hub using the wireless technology. The system can quickly and accurately calculate water demand amount of crops, which can provide a scientific basis for water-saving irrigation, as well as a method to optimize the amount of fertilizer used (Wright, 1982).

Sensors used in monitoring system

Temperature sensor

SHT15 is small-sized, calibration, multifunction, intelligent sensor from the company of Switzerland sensory-on. It can measure relative parameters such as temperature, humidity and temperature measuring range is -40°C to $+123.8^{\circ}\text{C}$, resolution is 0.1°C , response time is less than 3 second. SHT15 is intelligent new sensor with free of calibration, free of debugging and almost no outer circuit. It does not require any external calibration or trimming to provide typical accuracies of degree C at room temperature. Low cost is assured by trimming and calibration at the wafer level. Its low output impedance, linear output, and precise inherent calibration make interfacing to readout or control circuitry especially easy. Temperature sensors are devices used to measure the temperature of a medium. There are two kinds of temperature sensors contact sensors and non-contact sensors. However, the three main types are thermometers, resistance temperature detectors and thermocouples. All three of these sensors measure a physical property (i.e. volume of a liquid, current through a wire), which changes as a function of temperature (Bogena *et al.* 2007; Zhang xihai *et al.* 2009; Zhang Feng, 2011).

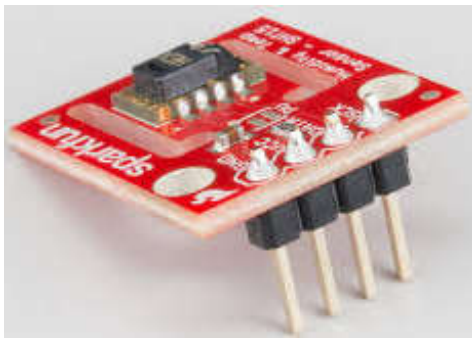

Fig.1. Sht15 temperature sensor

Humidity sensor

The humidity sensor used to measure the humidity of the field. It senses the field humidity and is connected to the IC NE555. First of all to set points of humidity from 54% to 80% for standard irrigation but it changeable according to the climate and the type of the soil. The humidity sensors plays an important role in this project that it senses the moisture levels and gives instructions to the IC NE555 and the motor can start and stop based upon the moisture levels.



Fig. 2.HIH 4000 humidity sensor

Humidity sensors play an important role in a industrial application areas. Most humidity sensors are important in a semi conductor area while wafer process and in Medical applications process in a respiratory equipment. A humidity sensor senses relative humidity. This means that it measures both air temperature and moisture. Relative humidity,

expressed as a percent, Theirs the ratio of actual moisture in the air to the highest amount of moisture air at that temperature can hold (Morris, 2008; Swarup *et al.*, 2012; Anderson *et al.*, 2013).

Soil moisture sensor

A soil moisture sensor as the name indicates is used to determine the moisture present in the soil. The moisture of the soil depends upon various factors such as type of soil whether its sandy, clay, loam, sandy loam and salts present in soil such as iron, manganese, calcium, phosphorus, nitrogen, sulphur etc. it also depends upon temperature. Based on the reading of moisture sensor, irrigation is done. Soil moisture sensors can be classified into following types based on the methods to determine the soilmoisture. It shows how a sensor obtains moisture from the soil. Then these values are compared with the desired value entered by the user. (a) soil volumetric water content based sensors are used to determine the amount of water present in the soil. Its unit is mass (g/g) or volume (cm^3/cm^3). (b) soil water tension based soil moisture sensors measure energy of water in the soil. It says how much difficult or easy it will be for the plant to extract the water from the soil. Its unit is joules/kg or kilopascal (kpa) (McCann *et al.* 1992; Shock *et al.*, 1998; Swarup *et al.*, 2012; Vimal Mishra *et al.*, 2013; Purnima and Reddy, 2012).

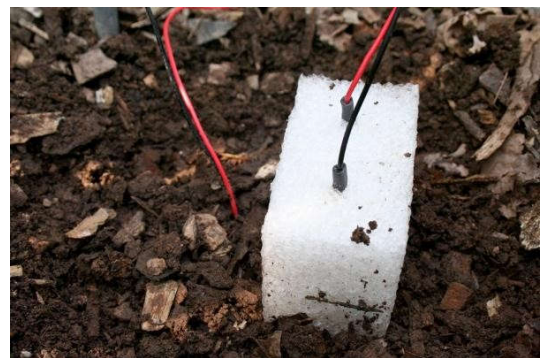

Fig. 3. Soil moisture sensor

Water level sensor

This sensor detects the level of substance that flow including liquids, slurries, granular materials and powders. Fluids and fluidized solids flow to become essentially level in their containers (or other physical boundaries) because of gravity whereas most bulk solids pile at an angle of repose to a peak. The substance to be measured can be inside a container or can be in its natural form (e.g., a river or a lake). The level measurement can be either continuous or point values (Zhang Feng, 2011).

- point level sensors only indicate whether the substance is above or below the sensing point. Generally the latter detect levels that are excessively high or low.
- Continuous level sensors measure level within a specified range and determine the exact amount of substance in a certain place. Liquid level sensors and switches provide high-reliability monitoring and detection of a wide range of fluid media.



Fig. 4. Water level sensor

Drip Irrigation system

Drip irrigation

Drip irrigation activated by distributing water directly to the soil at a very low rate from a system of small diameter plastic tubing fitted with outlets called emitters or drippers. Drip irrigation is highly efficient because the water absorbs into the soil before it can evaporate or run off. The water is also applied close to the plant root zone providing a high moisture level in the soil in which crops can thrive. The main components of a drip system consists of a main line, valve, backflow preventer, pressure regulator, filter, tubing, adapters and fittings, drip tubing, emitters and an end cap. Venturi injectors are used before the main line to inject any fertilizers, pesticides or insecticides into the water stream. The drip irrigation in this system is activated after the controller gets the confirmation message from the user.

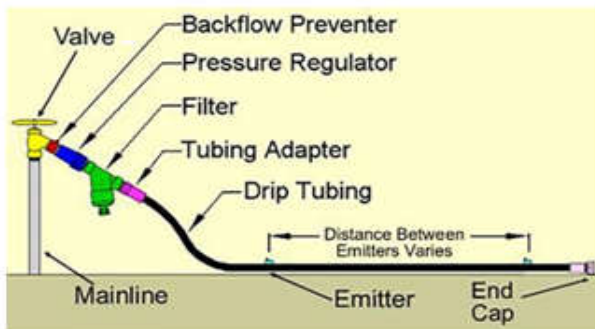

Fig. 5. Drip irrigation system

The drip irrigation system is used as it saves up to 90% of the water used for irrigation. The amount of water which is lost to evaporation is also very low and the water is directly supplied to the roots which results in systematic growth of the plant (Wright, 1982).

Mobile technology

The mobile technology keeps the user updated and in control of the irrigation system from a remote location. The amount of water evapotranspired is calculated using Penman-Monteith Formula. GSM (global system for mobile communications) is a

Second generation digital mobile telephone standard using a variation of Time Division Multiple Access (TDMA). It is the most widely used of the three digital wireless telephone technologies - CDMA (Code Division Multiple Access), GSM and TDMA. GSM digitizes and compresses voice data, then sends it down a channel with two other streams of the reference crop type (bulk surface resistance, and aerodynamic roughness of the surface) and daytime/night time ratio.

Working

Initially a mobile GSM device is connected to the controller (Set in auto answering mode). Another mobile device is operated by the user. The parameters (Humidity, Temperature, Wind Speed and Radiation) are measured by the many real-time wireless sensors placed in the field. At an interval of 12 hours, using the Penman-Monteith Formula, the water evapotranspired is calculated. Based on the value of ET_0 , the amount of water to be used for irrigation is determined. Using the mobile device connected to the controller, a confirmation message is sent to the user's device. If the user approves, the controller opens the main line valves of the irrigation system for the particular amount of time. There is a main source for purified water. Storage tanks can be included for pesticides and insecticides. Using Venturi injectors, these chemicals are mixed in proportion with the water in the main line.[9]

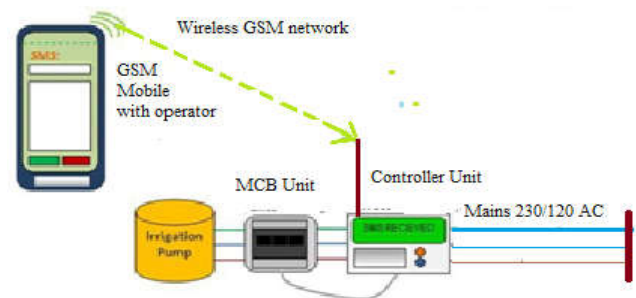

Fig. 6. Drip irrigation system using mobile technology

Venturi injector

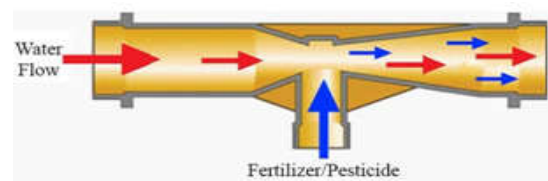

Fig. 7. Venturi Injector

The mobile technology saves more than 50% of water. C. The control stage. The control stage interfaces the *desired* soil moisture and the measured soil moisture (from the "soil" stage). This stage is intended to keep the actual soil moisture as close as possible to the desired moisture. Its output is the valve control value, which represents the amount of water that should be added to the soil continuously in order to maintain a minimal deviation (Feldhake *et al.*, 1983).

$$ET_o = \frac{0.408\Delta(R_n - G) + \gamma \left(\frac{C_n}{(T + 273.16)} \right) u_2 (e_s - e_a)}{\Delta + \gamma(1 + C_d u_2)}$$

Crop system

Productivity of agriculture depends on matching water supply with crop demand and by irrigation the field accordingly. To determine the crop water demand, it is essential to estimate and measure the humidity of soil. The downfall of ground water level is measure problem which is due to unawareness of farmers about irrigation methods and various techniques. So to solve this problem an adequate amount of water is required to grow a crop, which is effected by various factors. The climate changes, per day requirement of water by the crop according to the type of crop, daily weather condition and its growth. In this section it will explain about rainfall with different type of crop having different growth stage: initial stage, crop develop stage, mid season, late season.

GUI system

A graphical user interface or GUI, pronounced is a type of interface that allows users to interact with electronic devices through graphical icons and visual indicators such as secondary notation, as opposed to text-based interfaces, typed command labels or text navigation. GUIs were introduced in reaction to the perceived steep learning curve of command-line interfaces (CLIs), which require commands to be typed on the keyboard. The analysis consists of three stages: in the first stage work consist of assembling different component in a synchronized manner to sprinkle the water in the whole field. In this section, the subject under consideration is the motor pump connected to the water tank. The pump is designed to sprinkle or absorb the field water according to conditions. Second stage includes the sensing of the soil moisture using STH-15 which is a temperature sensor. Third or last stage is checking for water level of the storage tank. This section is used for overall surveillance and control of the system using programmed GUI window. In automatic mode the sensor acquires soil data in analog form and converts it to its proportional humidity value according to the step size. Initially, crop type is defined with its stage to approximate the calculation of crop water requirement. Both data difference is calculated and if the field condition is below requirement, the controller pumps water to the field to fulfill crop demand. If the water content is high then pump rotation reverses to drive out excess amount of water from the field. The extracted water is conserved by connecting pipe to the waste separator system which is generally used for rainwater harvesting (Gupta *et al.*, 2014).

High rainfall control unit

This system is useful control the excess watering, wastage of electricity and result in better and proper agriculture environment for crops. But heavy rainfall is major problem, which leads to over irrigation and water seeping. The initial stage of crop is very sensitive towards excess amount of water; it may ruin the whole field. But at the same time some stages of crop require more and more water. In case of heavy rainfall crossing the crop water requirement barrier, the irrigation control unit activates new GUI linked it. This system pumps out the excess amount of water and stores it in water reservoir. Then it is passed via waste separator chamber. It is a low cost spring mass system where a plank with tiny pores is connected

to the spring attached at the top of the chamber. Water flows from pipe to the chamber by pushing flap and crosses the plank through pores (Brouwer *et al.*, 1986).

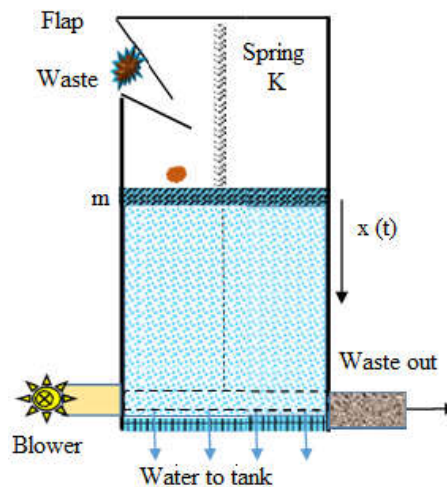

Fig. 8. High rainfall control unit

Whereas waste particles accumulates on plank surface increasing the relative mass while waste free water flows out of the chamber to the tank opening. It also prevents soil erosion as the system pumps out running water into tank and reuse it for irrigation. As the mass increases the plank moves down, displacement occurs. The blower turns ON to blow away the waste particle through remove opening.

Water need dependency on crop type and stage

The influence of crop type with its different stage is analyzed. The relationship between the reference grass crop and the crop actually grown is given by the crop factor k_c as shown in the following formula:

$$E_{T0} * K_C = E_{TCROP}$$

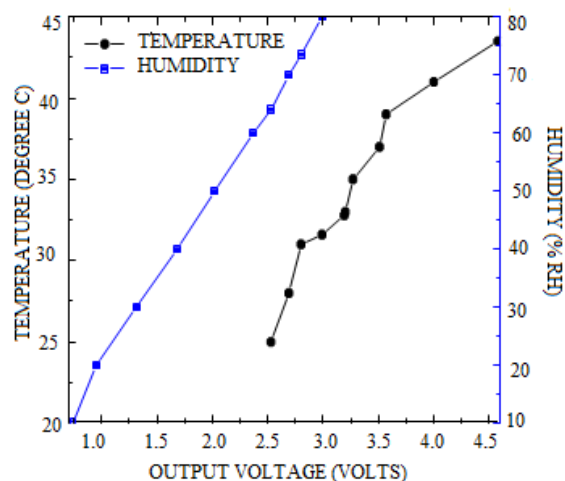

Fig. 9. Soil Humidity and Temperatuer sensor

The value of crop factor depends on crop's total growing period and its different growth stage. These factor are used for the approximation of crop water requirement. For irrigation

purpose water level in reservoir is an important factor. Generally bottom pressure of the tank used for determining the level of water (Allen *et al.*, 1998).

Submersible motor



Fig. 10. Submersible motor

Submersible motor which place vertically under the water and the electrical input drive. It connects the pump body and motor at on the rating of a submersible motor is a 12v, 200 rpm and 2.24A. It is important that the motor have an adequate flow of water passing it to maintain proper operating temperature. If the well casing is “oversize” or the motor is installed in a “pit” or “pond”, or the inflow from the well is above the pump, a closed top shroud of the proper size must be installed above the pump suction inlet to force the liquid to pass the motor before entering the pump (Ishwar Kumar *et al.*, 2014).

Water Pumping System

It checks the moisture content in the soil, based on that pumping motor will automatically pumps the water into the field. Here we are using soil moisture sensor. By using this sensor, we can find whether the soil is wet or dry. If it is dry, pumping motor will pump the water. In this system, the main controlling device is IC NE555. Here soil sensor will give the status of the soil to the IC NE555, based on that IC will display the status of the soil on the LCD and switch on or off the pumping motor through relay. The pumping motor will pump the water into the field by using drip water system until the field is wet which is continuously monitor by the IC. In irrigation process, most parameter of monitoring is soil, so it must be monitor the soil condition, whether the soil is dry or wet. If it is dry, then by using pumping motor, water has to be pumped automatically. The main aim of our system presenting here is to monitor the moisture content in the soil in cultivating field. Based on soil moisture, pumping motor will be automatically switch on or off through relay. This saves the water at the same time and on the other hand the plant can get optimum level of water, so increasing productivity of crop (David *et al.*, 1992-1997).

Elements used

Supply	230V, AC supply
Resistor R1	220K
Resistor R2	10K
Resistor R3	3.9K
Resistor R4	120K
Resistor R5	2.2K
Capacitor C1	1000 micro farad

Capacitor C2 & C4	0.1 micro farad
Capacitor C3	0.047 micro farad
Diodes D1 & D2	1N4007
Transformer	12V
Transistor T1 & T2	BC547
Transistor T3	SL100
Water sensing probe	
IC	NE555
IC Socket	8 pin
Regulator IC	7805
Relay (SPDT)5V	

Power supply

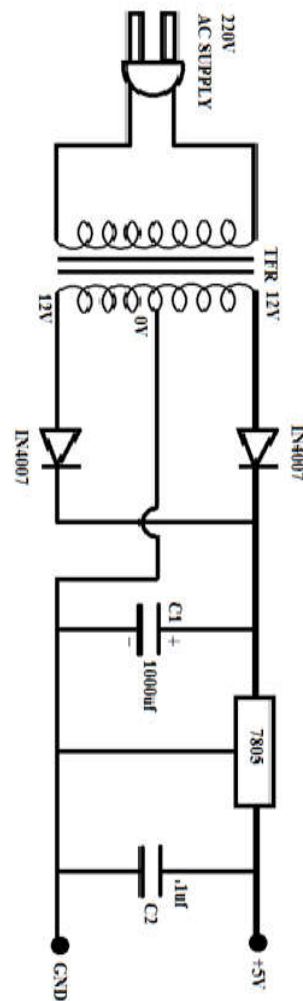

Fig. 11. Power supply

Working

Firstly, the transformer has provided with AC supply voltage 220V. The transformer step down this 220v to 12v. We have used two diodes D1 and D2. They are forming a full wave rectifier diode. It is converting AC to DC. Now this DC that has been obtained is used for the operation of the rest of the circuit. Capacitor C1 (1000µf) is used to filter the DC output of full wave rectifier. Capacitor C2 is used to reduced noise effect. Water sensing probe is used which sense the water level upto given parameters. It will be connected to the base of transistor T1 (Jerry, 2003). Pump will be continuously running till the earth is dry. It will be stop when it sense wet earth.

Circuit diagram

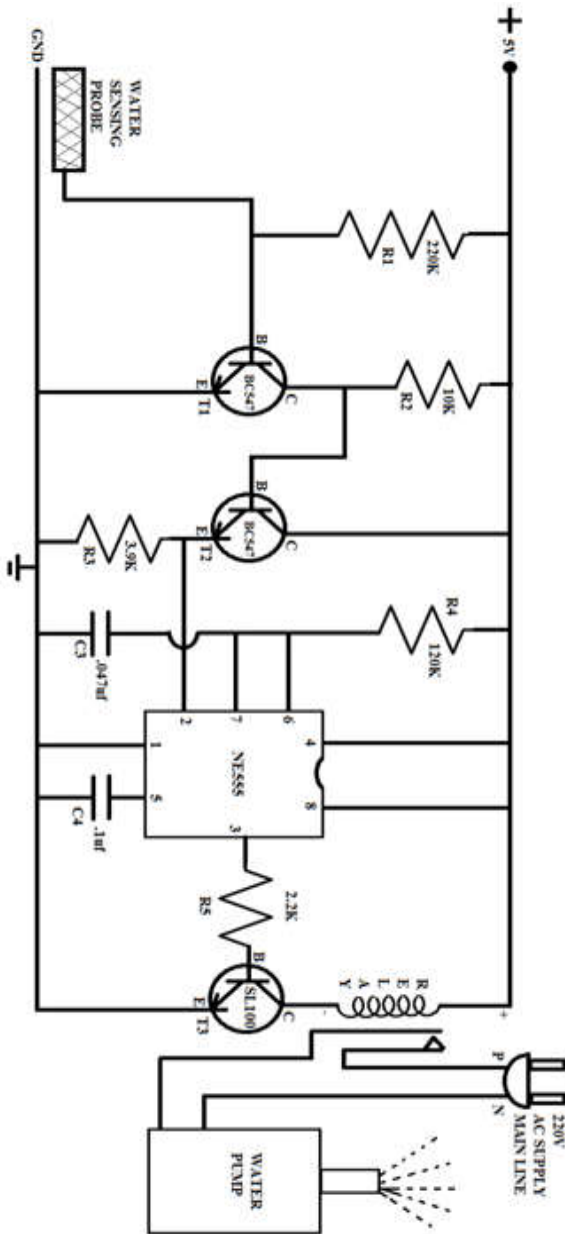

Fig. 12. Circuit diagram

Working

In the circuit diagram two transistors T1 and T2 are cross coupled. The collector of transistor T1 drives the base of transistor T2 through the resistor R2. The collector of transistor T2 drives the base of transistor T1 through resistor R1. When one of the transistor is in the saturated state, the other transistor will be in the cut-off state. If we consider the transistor T1 to be saturated, then the collector voltage will be almost zero. Thus there will be a zero base drive for transistor T2 and will go into cut-off state and its collector voltage approaches +Vcc. This voltage is applied to the base of T1 and thus will keep it in saturation. Now, let the transistor T1 to be in the cut-off state, then the collector voltage of T1 will be equal to +Vcc. This voltage will drive the base of the transistor T2 to saturation. Thus, the saturated collector output of transistor T2 will be almost zero. This value when feedback to

the base of the transistor T1 will drive it to cut-off. Thus, the saturation and cut-off value of anyone of the transistors decides the high and low value of Q and its compliment. By adding more components to the circuit, an R-S flip-flop is obtained. R-S flip-flop is a circuit that can set the Q output to high or reset it low. Incidentally, a complementary (opposite) output Q is available from the collector of the other transistor. The schematic symbol for an S-R flip flop is also shown above. The circuit latches in either the Q state or its complimentary state. A high value of S input sets the value of Q to go high. A high value of R input resets the value of Q to low. Output Q remains in a given state until it is triggered into the opposite state (Dinesh et al., 2012).

IC NE555



Fig.13. Pin Diagram of IC ne555

Submersible Pump



Fig. 14. Submersible pump

The submersible pump is a type of construction in which the driving motor is coupled directly to the turbine bowl assembly and is designed to be submerged in the fluid pumped. Power is supplied to the motor by means of waterproof electrical cable running from the motor to the power source.

Applications

- Irrigation in fields.
- Irrigation in Gardens, Parks.

- Very efficient paddy, rice field.
- Pisciculture.
- Automation system.
- Process industries.
- Soil less farming.

Conclusion

- In present days especially farmers are facing major problems in watering their agriculture fields, it's because they have no proper idea about when the power is available so that they can pump Water. Even after then they need to wait until the fixed is properly watered, which makes then to stop doing other activities.
- Several things must be considered to get the right system
- Many reasons available to make decision.
- Many choices for field water content measurement.

Future Extension

The working of project is basically dependent on the output of the humidity sensors. Whenever there is need of excess water in the desired field (RICE CROPS) then it will not be possible by using sensor technology. By using this we be able to irrigate the desired field and in desired amount.

REFERENCES

- Allen, R. G., L. S. Pereira, D. Raes, and M. Smith, 1998. Crop Evapotranspiration-Guidelines for Computing Crop Water Requirements—FAO Irrigation and Drainage Paper 56. Rome, Italy: FAO.
- Anderson, W. B., Zaitchik, B. F., Hain, C. R., Anderson, M. C., Yilmaz, M. T., Mecikalski, J., Schultz, L. 2013. Towards an integrated soil moisture drought monitor for East Africa. *Hydrol. Earth Syst. Sci. Discuss.*, 9:4587–4631
- Bogena, H. R., Huisman, J. A., Oberd Êrste, r C., et al. 2007. Evaluation of a low cost soil water content sensor for wireless network applications[J]. *Journal of Hydrology*, 32 42.
- Brouwer, C., Heibloem, M. 1986. Irrigation Water Management. Training Manual, vol. 3. Prov. ed., 60 pp. Rome, Italy: FAO.
- D., 2005. Soil water sensors placement and interpretation for drip irrigation management in heterogeneous soils. In: Proceeding of 5th International Microirrigation Congress
- David, L. B., Tian, G., Tim, R., McVicar, Qin Yi, Li, F. Soil Moisture and Drought Monitoring Using Remote Sensing, Final Report Australia-China Joint Science and Technology Commission Project. 1992-1997. CSIRO Australia.
- Dinesh, M., Saravanan, P. 2012. FPGA Based Real Time Monitoring System for Agricultural Field. *International Journal of Electronics and Computer Science Engineering*, 1(3):1514-1519.
- Feldhake, C.M., R.E. Danielson, and J.D. Butler, 1983. Turfgrass evapotranspiration: I. Factors influencing rate in urban environments. *Agron. J.* 75:824–830.
- Gupta, S.K., Sharma, R. and Saket, R.K. 2014. 'Effect of variation in active route timeout and delete period constant on the performance of AODV protocol', *Int. J. Mobile Communications*, Vol. 12, No. 2, pp.177–191.
- Ishwar Kumar, Jatin Vij, Leen Vitthal bhai Patel, Mayank Sharma, Devasis, H. 2014. [a]l]dar, solar power irrigation systems; *International Journal Of Engineering Research & Management Technology*, (ISSN: 2348-4039), March, Volume-1, Issue.
- Jerry, C. R., Paul, V. Z., James, H. E. 2003. Remote Sensing Techniques to Assess Water Quality. *Photogrammetric Engineering & Remote Sensing*, 619–630. 5.
- McCann, I.R., D.C. Kincaid, and D. Wang. 1992. Operational characteristics of the watermark model 200 soli water potential sensor for irrigation management. *Appl. Eng. Agric.* 8:603-609.
- Morris, M. 2008. Soil Moisture Monitoring: Low-Cost Tools and Methods. NCAT Energy.
- Purnima and SRN Reddy, 2012. Article: Design of Remote Monitoring and Control System with Automatic Irrigation System using GSM- Bluetooth. *International Journal of Computer Applications* 47(12):6- 13, June, Published by Foundation of Computer Science, New York, USA.
- Shock, C.C., J.M. Barnum, and Seddigh, 1998. "Calibration of watermark soil moisture sensors for irrigation management", pp. 139-146 in proceedings of the international irrigation show, irrigation association, San Diego, CA.
- Swarup, S. M., Chaudhari, D. S. 2012. A Review on Smart Sensors Based Monitoring System for Agriculture. *International Journal of Innovative Technology and Exploring Engineering*, 2(4):76-78.
- Vimal Mishra, I. S., Naveen, Subhadeep Purkayastha, Swastik Gupta, 2013. Design of Adaptive Humidity Controller and Practical Implementation for Humidity and Temperature Exclusiveness. *International Journal of Advanced Research in Computer Science and Software Engineering*, 3(6), June, pp.300-305.
- Wright, J.L., 1982. New Evapotranspiration Crop Coefficients Journal of Irrigation and Drainage Division, *ASCE, J* 108:57-74.
- Zhang Feng, 2011. "Research on water saving irrigation automatic control system based on internate of things", electric information and control engineering (*ICEICE*). *International conference*, vol.4, no.1, pp.2541-2544, 15-17.
- Zhang xihai, 2009. Zhang changli Fang junlong. Smart Sensor Nodes for Wireless Soil Temperature Monitoring Systems in Precision Agriculture, 237-241.
