



Full Length Research Article

EMBEDDED SYSTEM DESIGN FOR MEASUREMENT OF DIELECTRIC CONSTANT OF CONDUCTING POLYMERS AT MICROWAVE FREQUENCIES

***Vijaya Bhaskar, M. and Dr. Padma Suvarna, R.**

Department of Physics, JNTUA, Anantapuramu, Andhra Pradesh, India

ARTICLE INFO

Article History:

Received 05th December, 2014
Received in revised form
10th January, 2015
Accepted 22nd February, 2015
Published online 31st March, 2015

Key words:

Microcontroller,
Stepper motor,
X-band Microwave bench,
Conducting polymers.

ABSTRACT

This paper deals with the design of an embedded system for acquiring the dielectric constant using microcontroller controlled stepper motor. Dielectric parameters of general materials are measured manually by using x-band Microwave bench. These measurements are not much accurate when done manually. Hence, microcontroller based automatic measurement of the dielectric parameters is designed. Microcontroller based stepper motor moves on the microwave bench and measures distance up to a fraction of mm to nanometer per step. This technique gives high precision for the measurement of guide wavelength (λ_g). Further accuracy of this technique can be increased if the stepper motor is operated in micro configuration.

Copyright © 2015 Vijaya Bhaskar, M. and Dr. Padma Suvarna, R. This is an open access article distributed under the Creative Commons Attribution License, which permits unrestricted use, distribution, and reproduction in any medium, provided the original work is properly cited.

INTRODUCTION

The operations done manually are replaced with automatic control system which consists of Machines, advanced electronic techniques and computers. Manually the plunger in X-band microwave bench can move 1mm approximately at a time in forward or backward direction. For that Stepper motors are widely used where precise motions are required. In this special logic and high-current drive circuits are required to drive stepper motors. Microcontroller is used to control the steps of the stepper motor in clockwise and anticlockwise direction. It is also used to display the movement of stepper motor clockwise and anti clockwise direction. This design explains the use of single microcontroller to control the speed, direction and rotation angle of a stepper motor by sending pulse sequences to the motor winding in response to the commands. Control commands executed by the code here include a single step motor rotates in a clockwise or counter clockwise direction and the sequence of input pulses is directly related to the direction of motor shaft rotation. The speed of motor shaft rotation is related to frequency of the input pulses and the length of rotation. The microcontroller based automation technique gives high precision.

Stepper Motor

For automation, Stepper motor is one of the most useful devices. It is convenient and versatile bridge between a set of motion rules. It can be moved gradually, rapidly, in opposite, pause, complete revolutions, partial revolutions and even individual steps of less than a degree of rotation. With this flexibility of movement coupled with an abundance of torque for relatively little power applied. In Stepper Motor a full rotation is divided into a number of steps. For a fixed DC voltage the stepper motor rotates in discrete step angles. The Stepper Motors are designed with microsteps per revolution and Gear reducers can be used to increase resolution of positioning and microsteps from 350 to 26000 per revolution can be used. The motor's position can be made to move and clamped at one of these steps without any feedback sensor. The stepper motor used here, has 5 leads in which 4 leads represent the four stator windings and 5th lead is used for centered-tapping. When sequence of power is applied to each stator winding the rotor will rotate. There are many sequences where each has a different degree of precision. In a full step sequence, two coils can be energized at the same time and motor shaft will be rotated. The coils are energized to rotate the stepper motor in clockwise or anticlockwise direction. If the micro steps become lesser, motor operation becomes smooth, there by greatly reducing resonance in any parts.

***Corresponding author: Vijaya Bhaskar, M.**
Department of Physics, JNTUA, Anantapuramu, Andhra Pradesh

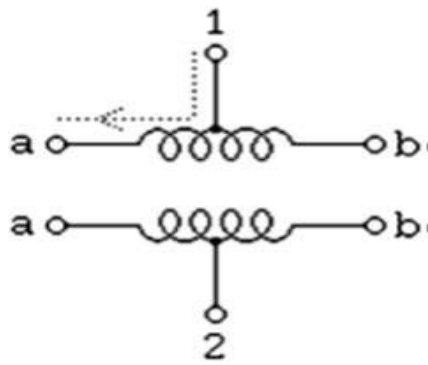

Fig. 1. Unipolar Stepper Motor Coil

The system is built around the microcontroller. In this system a unipolar stepper motor is used with other functional units. Unipolar stepping motors with 5 or 6 wires are available and usually wired as shown in Fig.1 with terminal 1 and 2 center tapped on each of the two windings. Generally, the center taps of the windings are wired to the positive supply and the two ends of each winding are alternately grounded to reverse the direction of the field provided by that winding.

Experimental Details

Functional Block Diagram

This design consists of a micro controller, logic circuit, motor driver, stepper motor and X-band microwave bench conducting polymer cell. This technique moves the plunger in cell by fraction of mm or in nanometer per step. When the stepper motor is operated giving digital pulses in stepping mode in forward or backward direction it gives the maximum accuracy. The accuracy of this technique can be increased when the stepper motor is operated in micro stepping mode. The micro controller is used to operate the stepper motor and by software program written in Assembly level language. The stepper motor displaces the plunger in cell of the microwave bench in proper direction. The distance covered by the plunger in cell of the microwave bench forward or backward direction is also noted. Specifications: Maximum voltage: 24V DC, 1 Amp and in Step angle 1.8 degree Steps per revolution. The block diagram of PC based measurement technique is shown in Fig.2.

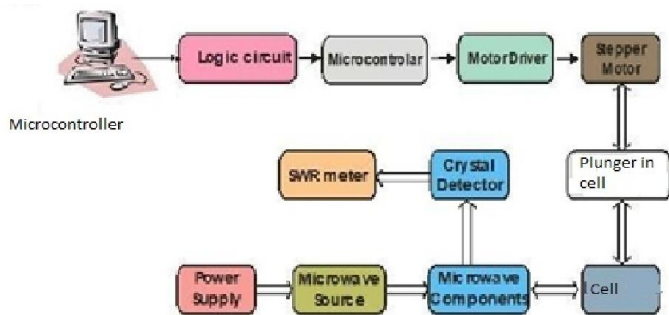

Fig. 2. Functional block diagram

Parallel port

The stepper motor is interfaced with microcontroller through 8 bit port. The ports are identified in micro controller by their base

address. The data bits (D0-D7) can be accessed at the base address. The data to be given out by microcontroller is the output at this base address, also called as the base register. To rotate the stepper motor in clock wise direction, we have to provide two values to the port with values 2 and 0 respectively, but in these two values we have to provide some time delay. To rotate the stepper motor in anti clockwise direction, we have to provide two values to the port address with the values are 3 and 1 respectively. Here too we provide some time delay.

Mechanical set-up of cell:

A rolled ball screw with high reliability and high accuracy of length 300 mm with ballnut is taken. The ball screw eliminates sanction between the ballnut and screw which avoids back-lash error. This also reduces elastic deformation. The ball screw will get much better rigidity with accuracy. The rolled ball screw has 4mm lead. The ball screw is fixed between two ball screw support units in the Mechanical assembly with leveling screws. The stepper motor axel is coupled with the rolled ball screw with the help of couple run it. The plunger in cell of Microwave bench is coupled with the ball nut. The Stepper motor is connected to driver and Control circuit is as shown in the fig. 3.

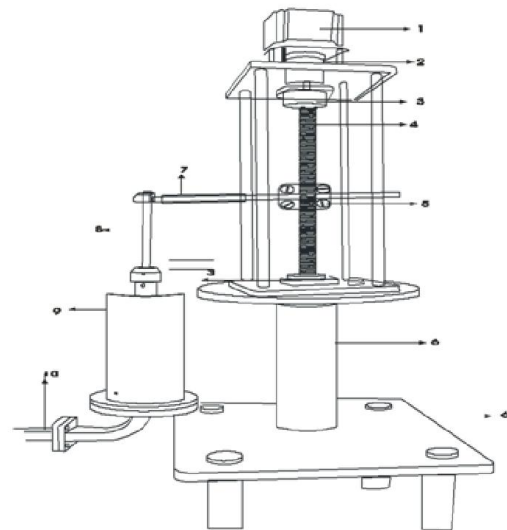

Fig. 3. Experimental setup of X- Band Microwave bench

Observations

The measurements of different physical parameters are measured by using Microwave bench. Here microcontroller based automatic measurement technique is used for accurate measurement of positions. The clockwise or anti clockwise rotation of the motor are controlled through microcontroller. The position (starting or ending) are measured as shown in Table 1, using the PC based automatic measurement technique. Microcontroller based stepper motor moves the plunger in cell of microwave bench as shown in fig.3.

Flow Chart

The flow chart employed to operate stepper motor for the plunger in cell is as shown in the fig. 3.

Table 1. Observation table for readings of Lengths in mm by using micro steps 26000 per revolution of stepper motor

R.No	Length	R.N	Length	R.No	Length	R.No	Length	R.No	Length
1	0.000146	16	0.00215	31	0.004944	46	0.006988	61	0.009731
2	0.000323	17	0.002756	32	0.005	47	0.007444	62	0.009788
3	0.000469	18	0.002823	33	0.005256	48	0.007505	63	0.009844
4	0.000635	19	0.003069	34	0.005413	49	0.007756	64	0.01
5	0.000801	20	0.003202	35	0.005569	50	0.007913	65	0.010256
6	0.000928	21	0.003291	36	0.005725	51	0.008069	66	0.010413
7	0.000999	22	0.003448	37	0.005881	52	0.008125	67	0.010469
8	0.001205	23	0.003694	38	0.006038	53	0.008281	68	0.010625
9	0.001416	24	0.003805	39	0.006194	54	0.008438	69	0.010881
10	0.001553	25	0.004006	40	0.006305	55	0.008594	70	0.011138
11	0.001729	26	0.004053	41	0.006496	56	0.00875	71	0.011094
12	0.001875	27	0.004229	42	0.006553	57	0.008906	72	0.011125
13	0.002131	28	0.004475	43	0.006739	58	0.009063	73	0.011506
14	0.002198	29	0.004631	44	0.006975	59	0.009219	74	0.011663
15	0.002444	30	0.004698	45	0.007131	60	0.009375	75	0.011819

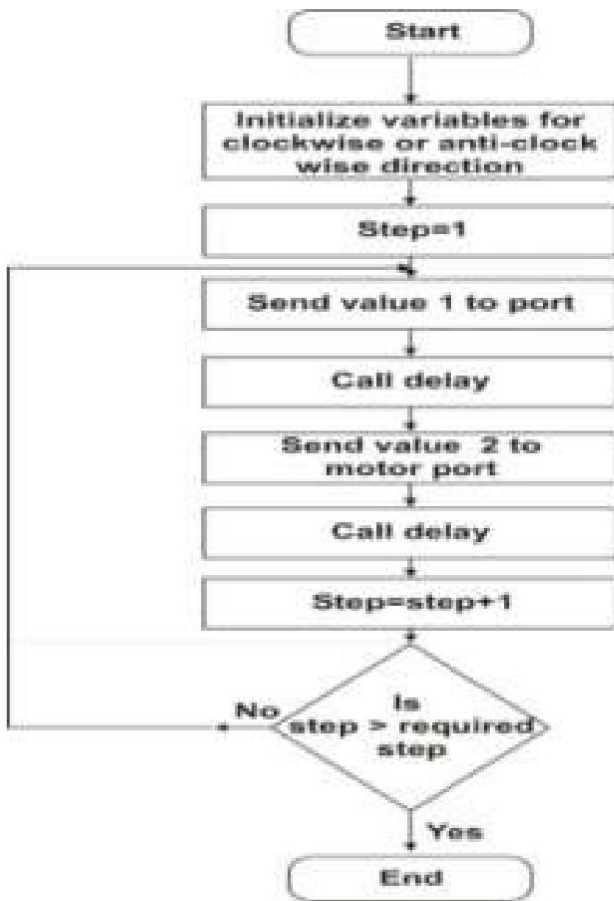

Fig. 3. Flow chart for program

Theory

A solid of length le is loaded in rectangular wave guide against short circuit that touches it well. If D & Dr are the positions of first voltage minima of the standing wave position when the wave guided is unloaded and loaded with conducting polymer then the respective distances from the short circuit will be $(l + le)$ & $(lR + le)$. Let β and β_e are the respective propagation constant. Expanding tangent sum angel

$$\frac{\tan \beta(Dr - D + le)}{\beta le} = \frac{\tan \beta_e le}{\beta_e le}$$

Where $\beta = 2\pi/\lambda_g$

The value of λ_g can be calculated using the formula

$$\left(\frac{l}{\lambda_0}\right)^2 = \left(\frac{l}{\lambda_g}\right)^2 + \left(\frac{l}{\lambda_c}\right)^2$$

Dielectric constant is given by

$$\epsilon_r = \frac{\left(\frac{a}{\pi}\right)^2 \left(\frac{\beta \epsilon le}{le}\right)^2 + 1}{\left(\frac{2a}{\lambda_g}\right)^2 + 1}$$

Where 'a' is the wave guide dimension, λ_c is twice the wave guide dimension and λ_0 is the ratio of velocity and frequency of microwave.

RESULTS AND DISCUSSION

The dielectric constant of different conducting polymers at S band frequency was compared and found that the dielectric constant decreases with increase in frequency. This is basically due to orientation polarization in the microwave field. As the frequency of the field increases the polarization has no time to reach its steady field and the orientation polarization falls firstly.

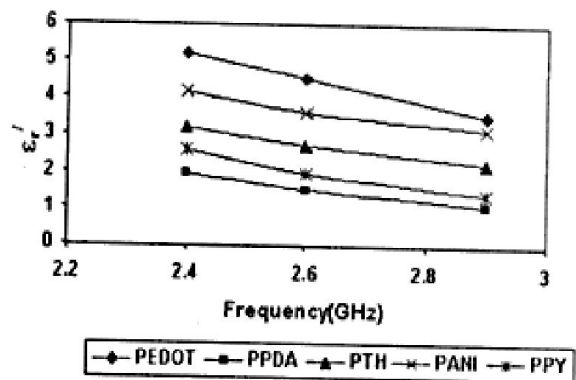

Fig. 4. Variation of dielectric constant with frequency for various conducting polymers. PEDOT, PPDA, PTH PANI AND PPY

It is also clear that dielectric constant is highest for PEDOT (3, 4-ethylenedioxythiophene) and gradually decreases in the order of PANI (Polyaniline), PTH, PPY and is lowest for PPDA (Polyparaphenylene diazomethane). The variation dielectric constant with frequency for various conducting polymers is as shown in the fig. 4.

Conclusion

The accuracy of the measurement of dielectric constant of conducting polymers can be increased to high extent. This measurement depends on only the measurement of guide wavelength λ_g . The main feature of this controller is its flexibility to provide high resolution operation for a stepper control motor control system. Analog to digital convertor maybe used for data acquisition. It is also found that dielectric constant show a trend in the reverse order PEDOT > PANI > PTH > PPY > PPDA. The dielectric properties of some important conducting polymers in the microwave and DC fields were successfully studied.

REFERENCES

- Mandeep Singh, Rekha and Balwinder Singh, 2010. International Journal of computer science & communication Vol.1, No.1, January- June2010, pp. 189-191
- Amenerkar, R.H., C.S. Adgaonkar, S.S. Yawale and S.P. Yawale, 2002. "Microwave properties of vanadium borate glasses", *MaterialScience*. 25, No.5, October, pp431-434.
- Choi, J. W. et al., 2004. *Synth Met* 141, 293-299.
- Baibarac, M and P. Gomez-Ramero, 2006. *J. Nanosci Nanotechnology* 6, 289-302.
- Kulkarni, M. 2004-2005. *Microwave and Radar Engineering*, Third Edition, Umesh Publication, pp 274276.
- Von Hippel, 1954. "Dielectric materials and applications", John and Sons New York, pp104-115.
- Duglas V. Hall. 1998. "Micro processor Interfacing and Programming". McGraw-Hill.
- Maida Muhammad Ali, 2007. "The 8051 Microcontroller and Embedded Systems", Prentice Hall of India, New Delhi, India, pp.492-507, Chap17.
- Hedges, B. 1993. *Industrial Robotics*, Jaico publishing House.
- Govindarajalu, B. 1998. *IBMPC and Clones: Hardware, Troubleshooting and Maintenance*, TMH, New Delhi, Ch.3, pp.63-102.

Proceedings Papers

- Baluta, G. and Coteata, M., 2007. "Precision Micro stepping System for Bipolar Stepper Motor Control", *IEEE International Conference on Electrical Machines and Power Electronics*, pp.291-296.
- Rusu, C. and Szoke, E, 2008. "Embedded System Design for Field-Oriented Stepper Motor Control", *IEEE International Conference on Optimization of Electrical and Electronic Equipment*, pp.63-68, May 2008.
- Rusu, C., Birou, I. and Szoke, E. 2008. "Model Based Design Controller for the Stepper Motor", *IEEE International Conference on Automation, Quality and Testing, Robotics*, 2, pp.175-179.
