



Full Length Research Article

OPTIMAL SHUNT CAPACITOR ALLOCATION AND SIZING USING HARMONY SEARCH ALGORITHM FOR POWER LOSS MINIMIZATION IN RADIAL DISTRIBUTION NETWORKS

***¹Muthukumar, K. ²Dr. Jayalalitha, S. ³Dr. Ramasamy, M. and ⁴Haricharan Cherukuri, S.**

¹Assistant Professor / EEE / SEEE, SASTRA University, Tirumalaisamudram Thanjavur, Tamilnadu, India

²Associate Dean / EIE / SEEE, SASTRA University, Tirumalaisamudram Thanjavur, Tamilnadu, India

³Professor / EEE, Annamalai University, Chidambaram, Tamilnadu, India

⁴PG scholar, SASTRA University, Tirumalaisamudram Thanjavur, Tamilnadu, India

ARTICLE INFO

Article History:

Received 08th January, 2014

Received in revised form

11th February, 2014

Accepted 15th February, 2014

Published online 14th March, 2014

Key words:

Radial Distribution System,
Harmony Search Algorithm,
Capacitor Placement,
Voltage Stability Index,
Backward /Forward Sweep,
based power flow technique.

ABSTRACT

This study aims to minimize the power loss in radial distribution networks which is realized by injecting reactive power with the aid of shunt capacitors installation at appropriate locations with optimal sizing. A population based meta-heuristic search algorithm namely Harmony search optimization algorithm is utilized for finding out the optimal rating of shunt capacitors to be placed in the radial distribution networks. A Backward / Forward sweep based iterative power flow technique is adopted to compute the load flow solution. The estimation of voltage stability index value of each bus in the proposed radial distribution systems helps to find the optimal locations of shunt capacitor to be placed for reactive power support and to achieve the loss minimization. The robustness of the proposed methodology for optimal shunt capacitor sizing has been tested on 22 and 119 node test systems. Simulation results reveal that the proposed optimization approach is more efficient in finding optimal solution.

Copyright © 2014 Muthukumar et al. This is an open access article distributed under the Creative Commons Attribution License, which permits unrestricted use, distribution, and reproduction in any medium, provided the original work is properly cited.

INTRODUCTION

In the distribution networks, the far end customers will be directly affected by low voltage problems due to more loss along the feeder lines and its sub laterals. The power loss associated with the Radial Distribution System (RDS) is more when compared with the transmission network due to its interest high R/X ratios, unbalanced loadings, untransposed feeder lines. To achieve the loss reduction in the distribution networks, various methods are proposed in the literature such as optimal conductor sizing, System Reconfiguration, shunt capacitor placement at appropriate locations with optimal ratings. Shunt capacitor installation at/or near to the loads improves the system efficiency if capacitors are to be optimally sized and located at appropriate locations. There is a chance of bus voltages exceeds the prescribed limit as a consequence of improper size of capacitor located at wrong places. An efficient distribution system load flow technique is needed for finding out the power losses as well as the node voltages and

the branch currents in the system at specified loading conditions. A load flow approach for solving the distribution system power flow problems which uses Triangular factorization known as implicit Z_{BUS} Gaussian method was proposed by Chen *et al.* in (1991). Shirmohammadi (1988) proposed a method for solving weakly meshed distribution systems by using basic Kirchhoff's laws and the proposed methodology can be applied for balanced as well as unbalanced networks. An approach for solving the power flow solution in radial distribution systems by using the Backward and Forward sweep has been proposed by Thukaram (1999). Das *et al.* (1995) suggested a methodology for power flow solution using the Backward & Forward approach. A quadratic equation approach for finding out the weaker nodes in the distribution networks has been proposed in (Gozel *et al.*, 2008) by Gozel. Various voltage stability indices available to find the weak nodes in the distribution system has been compared in (2009) by Eminoglu. A Voltage stability index suitable to identify the weak nodes in the RDS has been proposed by Chakravorty Das in (2001) considering the composite loading nature of the radial distribution systems. Sirjani *et al.* (2010) proposed the HSA based approach for capacitor placement (CP) for loss reduction. A network topology based power flow

*Corresponding author: Muthukumar, K. Assistant Professor / EEE / SEEE, SASTRA University, Tirumalaisamudram Thanjavur, Tamilnadu, India.

technique is proposed by Teng in (2000). Geem *et al.* in (2001) (Lee and Geem 2005) proposed new meta heuristic optimization technique namely Harmony search Algorithm (HSA) for solving the combinatorial optimization problems. HSA based optimal sizing of shunt capacitor has been suggested in (Muthukumar and Jayalalitha 2012; Muthukumar Jayalalitha and 2013) to reduce the cost of power loss along with installation cost of shunt capacitors. Ramalinga Raju *et al.* (Ramalinga Raju *et al.*, 2012) proposed a direct search algorithm for shunt capacitor placement in RDS.

Problem Formulation

In distribution network, power loss is a major concern which affects the consumers directly and one efficient way to reduce the power loss in the primary feeder lines is by installing the shunt capacitors which injects the reactive powers partially near to the consumer loads. The objective function of the proposed study is to curtail the power loss by reducing the reactive part of the branch currents and it can be stated mathematically as in Eq.(1&2)

Minimize

$$P_{loss} = \sum_{k=1}^{nb} P_{loss_k} = \sum_{k=1}^{nb} |I_{bk}|^2 \cdot R_k \quad (1)$$

$$k = 1, 2, 3 \dots nb$$

In a radial distribution network with “nb” number of branch sections, the total power loss can be stated as, $loss$

$$P_{loss} = \sum_{k=1}^{nb} (|I_{bk}|^2 R_k + |I_{bk}|^2 X_k) \quad (2)$$

$$k = 1, 2, 3 \dots nb$$

The total power loss is the summation of power losses associated with the real and reactive part of branch current magnitude in all the branches of the RDS as shown in Eq. (2). The proposed approach aims to reduce the total real power loss of the proposed test systems by reducing the reactive part of branch currents by partially injecting the reactive power using the shunt capacitors installation at appropriate locations with proper sizes. The following inequality constraints are to be satisfied for the proposed objective function minimization.

Bus voltage magnitudes

The bus voltage magnitude at each bus should lie in between the specified tolerance limits. $\pm 5\%$ of the nominal bus voltage as in Eq.(3).

$$V_{kmin} < V_k < V_{kmax} \quad k=1,2,\dots,n \quad (3)$$

Thermal loading limit of the feeder lines

The current through each branch of the feeder lines should be less than their maximum thermal limit

$$I_{bk} < I_{bkmax} \quad k=1,2,\dots,nb \quad (4)$$

Rating and total number of shunt capacitors

The multiple integers of the smallest size of standard capacitor available in the market with discrete sizes is one of the

constraints and the total reactive power supplied by the installed capacitors should not exceeds the total reactive power demand of the RDS

$$Q_{ck} \leq P_{Qc}, \text{ where } P=1,2,\dots,nc \quad (5)$$

$$\sum_{k=1}^{nc} Q_{ck} \leq Q_d \quad (6)$$

Power Flow Solution

The application of Newton Raphson or Gauss-Seidel methods for power flow solutions is not suitable for radial distribution system due to its higher R/X ratio and unbalanced loadings nature. To get the power flow solutions in RDS, various types of distribution load flow techniques were proposed and most of the methods are based on Kirchhoff's current law (KCL) and voltage law (KVL). Backward/Forward sweep based technique BPS is one of the efficient and most effective method used to get the power flow solution of RDS, which computes currents at all nodes from the end node towards the source node in the backward sweep mode and respective bus voltages are computed from source nodes towards the end nodes in the forward sweep mode (Teng 2000).

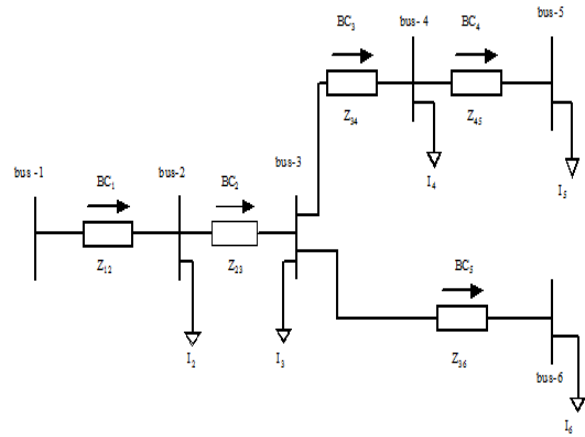

Fig 1. Sample radial distribution network

For the sample six bus RDS is shown in Fig.1, The current in each branches and bus voltages are calculated by using BFS based iterative technique. Equivalent current injected at k^{th} node is computed as in Eq.(7)

$$I_k = \frac{S_k^*}{V_k^*} \text{ where } k=2,3,\dots,n \quad (7)$$

where S_k^* is the conjugate of complex power of k^{th} node, V_k^* is the conjugate of k^{th} node voltage and “n” represents the total nodes available in the given radial network.

Formulation of BIBC matrix

After the computation of injected node currents, the corresponding branch currents (BC) are calculated as,

$$\begin{aligned} BC_5 &= I_6 \\ BC_4 &= I_5 \\ BC_3 &= I_4 + I_5 \\ BC_2 &= I_6 + I_5 + I_4 + I_3 \\ BC_1 &= I_6 + I_5 + I_4 + I_3 + I_2 \end{aligned}$$

where I_2, I_3, \dots, I_6 are the equivalent current injection of respective nodes.

The incidence matrix which relates the injected node current to branch current (BIBC) can be formulated as in Eq (8). The (BIBC) matrix dimension is nb x n, if the distribution system contains nb number of branches with n nodes.

$$\begin{bmatrix} BC_1 \\ BC_2 \\ BC_3 \\ BC_4 \\ BC_5 \end{bmatrix} = \begin{bmatrix} 1 & 1 & 1 & 1 & 1 \\ 0 & 1 & 1 & 1 & 1 \\ 0 & 0 & 1 & 1 & 0 \\ 0 & 0 & 0 & 1 & 0 \\ 0 & 0 & 0 & 0 & 1 \end{bmatrix} \begin{bmatrix} I_2 \\ I_3 \\ I_4 \\ I_5 \\ I_6 \end{bmatrix} \quad (8)$$

The above branch current matrix can be represented in a compact form as,
 $[BC]=[BIBC][I]$

Formulation of BCBV Matrix

The voltage of each node can be calculated from substation bus towards the terminal node after calculating the current injection by each load and branch currents beginning from the end node towards the root node. The incidence matrix which relates the branch current and bus voltage can be formulated as in Eq. (9)

$$(BCBV)=(BIBC)^T(Z_D) \quad (9)$$

Where “T” represents the transpose of (BIBC) matrix, and (Z_D) is the impedance matrix with impedance of each branch as the diagonal element as shown in Eq. (10).

$$(Z_D) = \begin{bmatrix} Z_1 & 0 & 0 & 0 & 0 \\ 0 & Z_2 & 0 & 0 & 0 \\ 0 & 0 & Z_3 & 0 & 0 \\ 0 & 0 & 0 & Z_4 & 0 \\ 0 & 0 & 0 & 0 & Z_5 \end{bmatrix} \quad (10)$$

Where Z_1, Z_2, Z_3, Z_4, Z_5 are the respective branch impedances of the sample system. The final form of (BCBV) matrix can be represented as in Eq. (11).

$$(BCBV) = \begin{bmatrix} Z_1 & 0 & 0 & 0 & 0 \\ Z_1 & Z_2 & 0 & 0 & 0 \\ Z_1 & Z_2 & Z_3 & 0 & 0 \\ Z_1 & Z_2 & Z_3 & Z_4 & 0 \\ Z_1 & Z_2 & 0 & 0 & Z_5 \end{bmatrix} \quad (11)$$

Then the bus voltages can be computed by using the (BCBV) matrix and branch current matrix (BC) as in Eq. (12)

$$\begin{bmatrix} V_2 \\ V_3 \\ V_4 \\ V_5 \\ V_6 \end{bmatrix} = \begin{bmatrix} V_1 \\ V_1 \\ V_1 \\ V_1 \\ V_1 \end{bmatrix} - \begin{bmatrix} Z_1 & 0 & 0 & 0 & 0 \\ Z_1 & Z_2 & 0 & 0 & 0 \\ Z_1 & Z_2 & Z_3 & 0 & 0 \\ Z_1 & Z_2 & Z_3 & Z_4 & 0 \\ Z_1 & Z_2 & 0 & 0 & Z_5 \end{bmatrix} \begin{bmatrix} BC_1 \\ BC_2 \\ BC_3 \\ BC_4 \\ BC_5 \end{bmatrix} \quad (12)$$

Where V_1 is slack bus voltage and it is taken as 1 p.u and the remaining bus voltages are assumed as 1.0 p.u for the first iteration in backward sweep mode for calculation of load

currents and the new value of bus voltages are updated as the iteration process progresses in forward sweep mode using Eq (12). This backward and forward sweep based iterative process is repeated until the convergence is reached.

Voltage Stability Index

The stability of the radial distribution network can be found by computing the voltage stability index (VSI) of each node. The stability index value near to 1.0 will be the indication of a stable system (Chakravorty and Das 2001). The candidate node with lower value of index is identified as the sensitive node and more chance for voltage collapse among all nodes and it is the well suited place for installation of shunt capacitors.

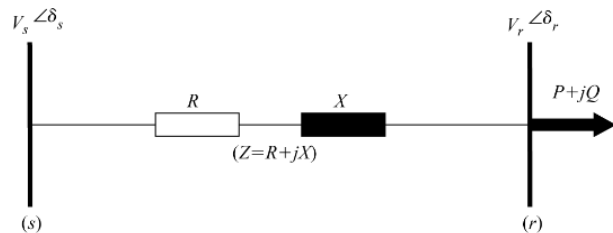

Fig 2. Branch of Radial Distribution Network

Where “r” indicates the succeeding node, V_s is preceding node voltage and V_r is the succeeding node voltage. P and Q represent the active, reactive power loads which are lumped at the succeeding node r. X and R are the effective reactance and resistance of the bus section. Using Eq.(13) the VSI of succeeding node r can be calculated as,

$$VSI(r) = \frac{\{|V_s|^4 - 4.0 |V_s|^2 \{P R + QX\} - 4.0 \{PX - QR\}^2\}}{\{P R + QX\}^2} \quad (13)$$

For stable operation of the radial distribution system with “n” number of nodes,

$$VSI (r) \geq 0, \text{ where } r = 2, 3 \dots n.$$

Harmony Search Algorithm

HSA has been proposed by Geem, Kim and Loganathan (Geem *et al.*, 2001; Lee and Geem 2005). It originated from the natural phenomena of music played on musical instruments. The improvisation is based on random process (or) based on musical experience of musician to attain pleasing harmony. In real world optimization problems based on the decision variables values, the objective function is evaluated and it can be improved via iterative process and finally a global solution is reached as like in finding the best pleasing harmony in HSA. The HSA algorithm is successfully applied in various benchmarking problems like data mining, visual tracking, traveling salesman problems and so on. It can be used effectively by choosing correct parameters and their values within their limits. The computational procedures of HSA are given below

Step-1: Parameters initialization of HSA algorithm.
 Step-2: Initialize of Harmony Memory Vector (HMV)
 Step-3: Improvisation process of the new Harmony Memory vector.
 Step-4: Updating the Harmony vector values.
 Step-5: Repeat step 3 & 4 until the termination criteria has been met.

Step- 1 Initialize the parameters of HSA

HSA parameters are initialized by choosing the suitable value for HM size. It is used to decide the number of decision vectors and in the HM, a group of decision variables are stored. The Harmony Memory Consideration Rate (HMCR) and Pitch Adjusting Rate (PAR) are utilized to get best solution vector to be stored in HM.

Step-2 HMV initialization

In Harmony Memory Vector (HMV), solution vectors are randomly generated within their lower and upper bound limits are utilized to form the HMS matrix

Step- 3. Improvisation of Harmony Memory (HMV)

The following three measures are adopted to improve the New Harmony vector value (10). The first one is Memory Consideration, second one is Pitch Adjustment and third one is Random Selection. The variable values of HM vector x_2, x_3, \dots, x_N are selected randomly. The HMCR value is chosen within 0 and 1, and it is the rate of selecting one decision variable value from the previously stored values in the Harmony Memor. (1- HMCR) is the rate of randomly choosing each decision variable value from the specified bound of values as in Eq. (14),

$$\begin{aligned} &\text{if } (\text{rand}() < \text{HMCR}) \\ & \quad x_i \leftarrow x_i \in \{x_i^1, x_i^2, \dots, x_i^{\text{HMS}}\} \\ & \quad \text{else} \\ & \quad x_i \leftarrow x_i \in X_i \\ & \text{end} \end{aligned} \quad (14)$$

$\text{rand}()$ represents the uniform random number lies within 0 to 1 and “ X_i ” is the possible range of values for each decision variable (x_i). if HMCR value chosen as 0.9, then the HS algorithm will select the decision variable from the values stored in the Harmony Memory with the probability of 90 %, (or) from the possible range lies between (100-90) % probabilities (Muthukumar and Jayalalitha 2012). Each element from the memory consideration is to be pitch adjusted as,

$$\begin{aligned} &\text{If } (\text{rand}() < \text{Pitch adjustment rate}) \\ & \quad x_i' = x_i \pm \text{bw} * \text{rand}() \\ & \quad \text{else} \\ & \quad x_i' = x_i \end{aligned} \quad (15)$$

“bw” represents a step size or random distance bandwidth.

Step-4. Updating Harmony Memory Vector (HMV). A new modified and improved harmony vector values and its best fitness function values computed in step 3 are added in HM by replacing the existing worst harmony vector. Otherwise, the new generated vector value is discarded. Step- 5: Step 3 and Step 4 are repetitive until the termination condition is reached.

RESULTS AND DISCUSSIONS

Methodology for identification of optimal location

A steady state voltage stability index for RDS to identify most sensitive buses that leads to voltage collapse are computed by using Eq. (13) to ensure the right place for capacitor installation. The node with lower value of VSI is considered as higher priority candidate node for placement of shunt capacitor. The VSI of each node in the proposed test systems has to be computed to find out the weak nodes. The bus voltage magnitudes, line flows and corresponding line loss are computed using the BFS based load flow technique. In HSA algorithm begins with random generation of the solution vectors without violating the constraints associated with the proposed objective function (i.e. random capacitor selection within the commercially available capacitor sizes). The HM matrix is filled with random solution vectors and its corresponding objective functions (real power loss) can be represented as (Muthukumar and Jayalalitha 2012),

$$\text{HMS} = (Qc_1, Qc_2, \dots, Qc_n)$$

In the subsequent iterative steps of HS algorithm, the stored vectors with its fitness values in the HM matrix are improved by eliminating the worst solution vectors by the improvisation steps such as memory consideration, Pitch adjustment rate, random selection process until the stopping criterion is reached. The proposed HSA algorithm is applied successfully for optimal sizing of capacitors on 22 node and 119 node test systems with real power loss minimization. The algorithm is implemented in Matlab 7.7.0 on a system with Intel core i5 processor. The selection of HSA parameters plays a vital role for the speed of convergence towards the global solution (Muthukumar and Jayalalitha 2013) The HSA tuning parameters are chosen for the proposed test systems after multiple test runs to demonstrate the algorithm effectiveness is shown in Table 1.

Table 1. HSA Parameters

Size of HM	10
HMCR	0.9
PAR	0.5
Total number of iterations	100

Example 1: Practical 22- Node radial distribution system:

The capacitor allocation problem using the proposed HSA based approach is implemented in practical 22 node agricultural distribution of Eastern power distribution system in India. The 22 node RDS data is obtained from (Ramalinga Raju et al., 2012). The base voltage is 11 KV and total system real and reactive power demand is 662.311KW and 657.4 KVAR respectively. The initial power loss before capacitor compensation is 17.67 KW. The optimal capacitors with its optimal location, active power loss before and after capacitive compensation are as shown in Table 2. The loss reduction obtained from 17.67 KW (base case) to 10.88 KW after shunt capacitors installed at node numbers 22, 21 and 20 with 150 KVAR, 194 KVAR and 186 KVAR respectively with active power loss reduction of 38.42%. The voltage stability index values before and after capacitive compensation is shown in

Fig.3 and it is pragmatic that the enhancement in the bus stability indices after capacitive compensation. It is observed that a significant bus voltage profile improvement is realized after capacitor installations at appropriate places with optimal ratings as shown in Fig 4.

Table 2. Simulation results of 22 Node test system

Real power loss (KW)		Optimal locations	Optimal capacitor sizes
Before CP	After CP		
17.67	10.88	22	150
		21	194
		20	186

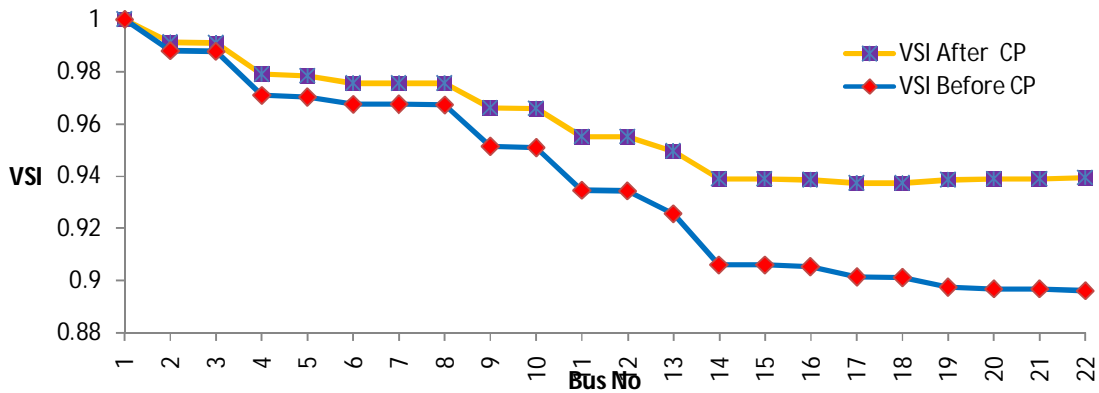

Fig 3.VSI at various nodes of 22 node test system before and after capacitor compensation

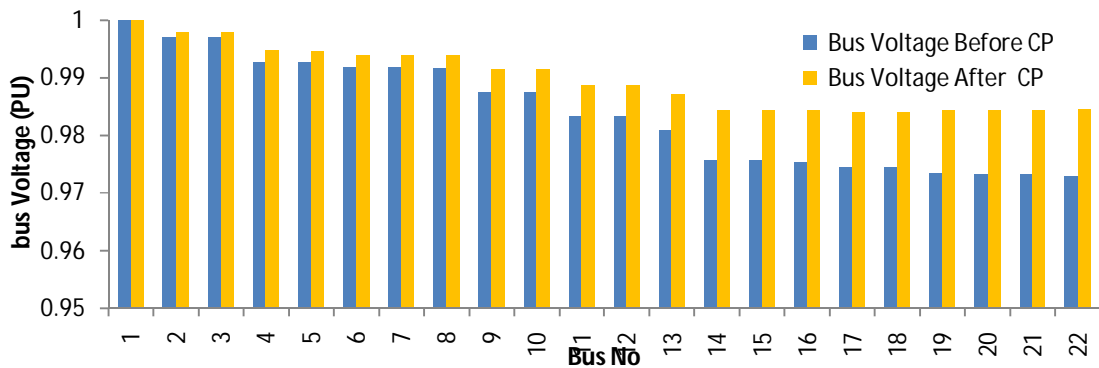

Fig 4. Bus voltage Magnitude of 119 node test system before and after capacitor compensation

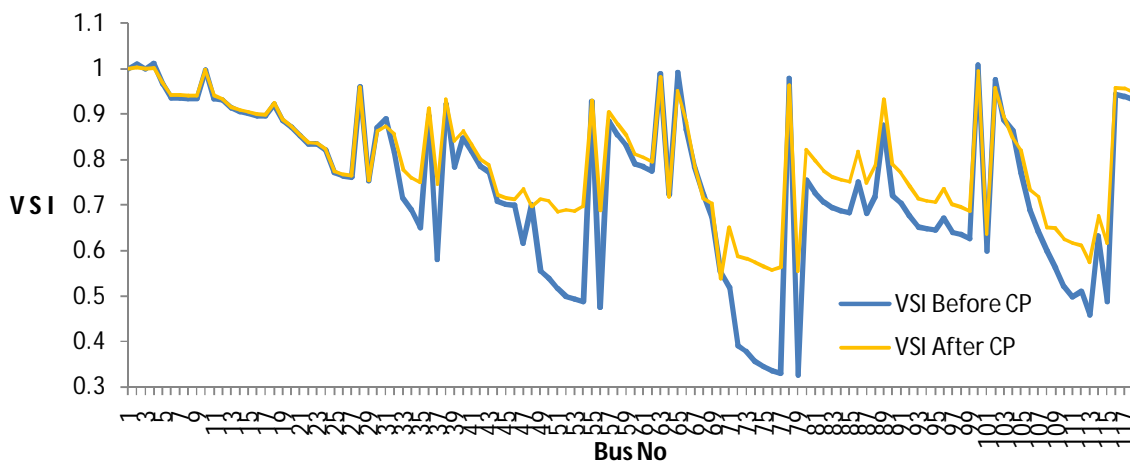

Fig 5. VSI at various nodes of 119 node test system before and after capacitor compensation

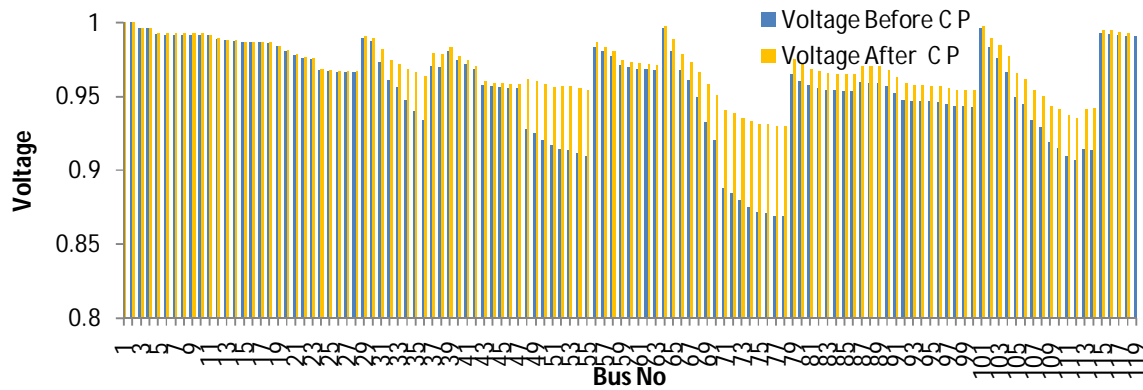

Fig 6. Bus voltage profiles of 119 node test system before and after capacitor compensation

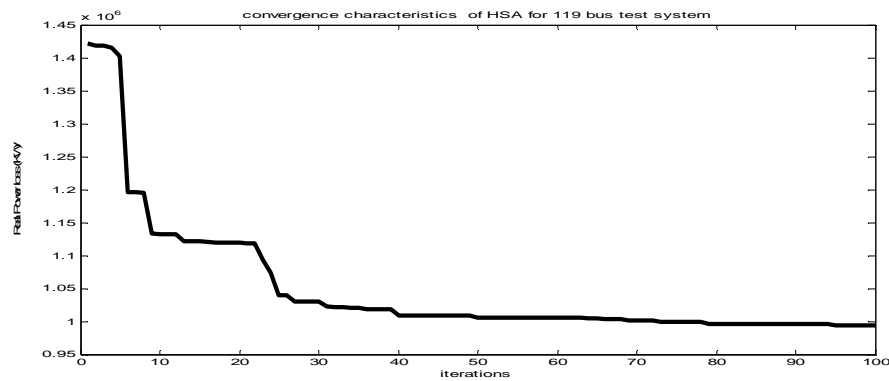

Fig.7. Convergence characteristics of proposed HSA for 22 node test system

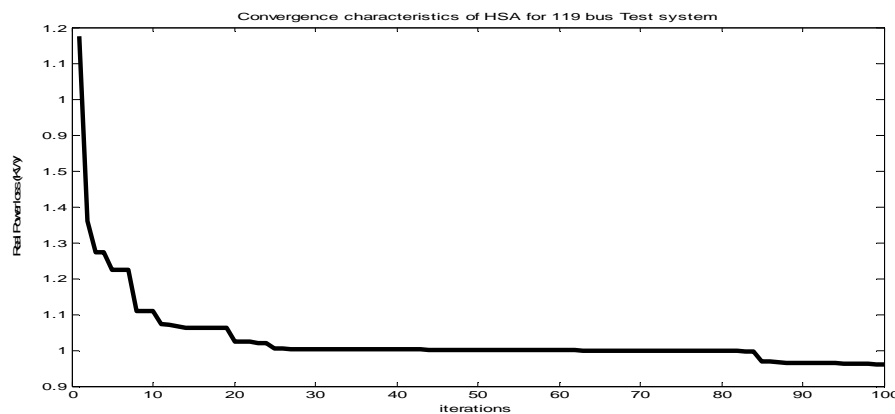

Fig. 8. Convergence characteristics of the proposed HSA for 119 node test system

Example-2: 119 bus test system

To investigate the efficiency of the proposed methodology in a large scale radial distribution network, it was implemented on 119 node test system contains 117 branches. The active and reactive load demand of the test system is 22709.72KW and 17041.07 KVAR respectively. The system is operated with the nominal bus voltage of 11 KV, 100 MVA base. The nodes of 119 bus test system have been renumbered as shown in Fig 9 and to preserve the radiality, the tie switches in the original test system (Dong Zhang *et al.*, 2007) have been removed. The load and line data is given in Table A1 and Table A2 in Appendix A. The BFS

based power flow technique is utilized to find out the bus voltage magnitude, line flows and total real power loss at nominal load condition and the real power loss obtained before capacitor placement is 1291 KW. The VSI values of all nodes in the proposed test network before and after capacitor placement are estimated using Eq.(13) and the corresponding VSI values are plotted as shown in Fig. 5. Based on the computed VSI values 21 nodes are identified as the sensitive nodes for capacitor placement and the amount of reactive power injection by the shunt capacitors is optimized by the HSA algorithm. The simulation results of optimal capacitor sizes and its corresponding locations, total system real power

loss before and after capacitor placements are summarized in Table 3. The bus voltage profile before and after capacitive compensation is shown in Fig.6. Simulation results reveal the effectiveness of proposed HSA algorithm to find the optimal capacitor sizes to achieve the power loss minimization from 1291 KW to 926.1KW (loss reduction of 28.26 %)

algorithm with different random population. The exploration and exploitation ability of the HSA algorithm towards the optimum solution for the proposed test systems are shown in Fig 7and Fig 8.

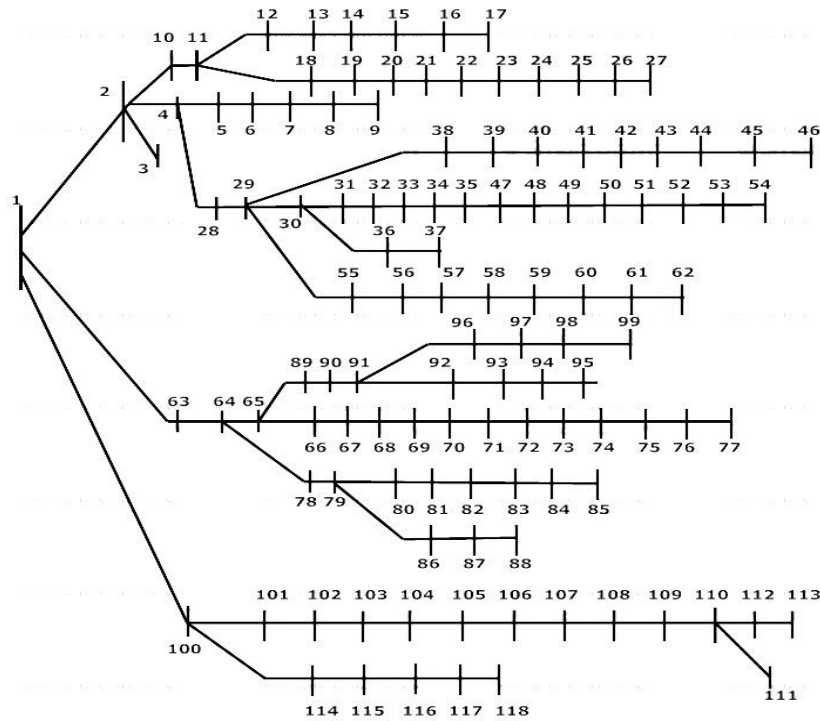

Fig 9. 119 bus radial distribution system

Table 3. Simulation results of 119 Node test system

926.1KW	
Optimal Locations	Optimal Capacitor sizes(KVAr)
79	714
77	170
76	192
75	509
74	272
73	432
72	386
113	974
56	375
115	493
54	377
53	425
111	641
52	753
112	793
51	349
71	513
110	281
50	165
70	626
49	488

Nomenclature

- nb :Total number of branches in m node RDS.
- Ploss : Total sum of real power loss in KW
- |I_{bk}| : Magnitude of k th branch current
- R_k : kth .branch conductor resistance in Ω
- X_k : kth.branch conductor reactance in Ω
- nc :Total number of capacitors to be installed
- nb : Number of branches in the RDS
- n : Number of nodes in RDS
- I_{brk} : kth branch current
- V_k : kth Bus voltage
- V_{k min} : Lower bound of kth node voltage
- V_{k max} : Upper bound of kth node voltage
- [BIBC] : Incidence matrix relates the node current injection to branch currents
- [BCBV] : Incidence matrix relates the branch currents to node voltages
- [BC] : Branch current vector
- [Z] : Impedance Matrix
- Q_c : Minimum Ratings of available capacitors.
- Q_d :Total KVAR demand of load in RDS
- I_{bkmax} : Maximum allowable k th branch current
- [I] : Bus current injection vector
- T : Matrix transpose

Convergence characteristics of HSA algorithm

The robustness of the HSA algorithm is tested by tuning the control parameters. Solution (real power loss) of the proposed test systems is obtained by 30 independent runs of the HSA

Conclusion

In this study, optimal capacitor allocation and sizing problem is solved by implementing Harmony Search Algorithm to

achieve the significant reduction in power loss along with the benefits such as improvement in bus voltage magnitude and voltage stability index of the proposed test systems. The convergence ability of the HSA towards the optimal solution has been demonstrated in large scale radial distribution system like 119 bus test system indicates its robustness to reach the optimal solution. The optimal location for capacitor installation is identified based on the VSI value of each node of the proposed 22 bus and 119 bus test systems and HSA has been utilized to find the optimal shunt capacitor ratings. It is concluded that the proposed HS algorithm is well suited to solve the nonlinear integer optimization problems.

REFERENCES

- Chakravorty M., D. Das, "Voltage stability analysis of radial distribution networks," *International journal of Electrical power and energy system*, vol.23, pp 129-135, 2001.
- Chen T.H., M.-S. Chen, K.-J. Hwang, P. Kotas, and E. A. Chebli, "Distribution system power flow analysis - A rigid approach," *IEEE Trans. Power Delivery*, vol. 6, pp. 1146–1152, July 1991.
- Das D., D. P. Kothari, and A. Kalam, "Simple and efficient method for load flow solution of radial distribution networks," *Electrical Power & Energy Systems*, vol. 17, N0.5, pp 335-346, 1995.
- Dong Zhang, Zhengcai Fu, Liuchun Zhang, "An improved TS algorithm for loss minimum reconfiguration in large scale distribution systems", *Electrical power system Research*, Vol 77,PP 685-694, 2007
- Eminoglu U. and M.H.Hocaoglu, "A Network topology based voltage stability index for radial distribution networks", *International Journal of Electrical Power and Energy Systems*, vol.29, no.2, pp 131-143, 2009
- Geem, Z.W., J.H.Kim and G.V.Loganathan, "A new heuristic optimization algorithm: Harmony search", *Simulation*, vol 76: no.2. PP:60-68,2001
- Gozel T., U. Eminoglu, M.H.Hocaoglu, "A tool for voltage stability and optimization (VS&OP) in radial Distribution systems using Matlab graphical interface (GUI)", *Simulation Modeling practice and theory*, vol.16,no.5, May2008, pp 505-518.
- K.Muthukumar, Dr.S.Jayalalitha, "Harmony Search Approach for Optimal Capacitor Placement and Sizing in Unbalanced Distribution Systems With Harmonics Consideration", *IEEE International Conference on Advances in Engineering, Science and Management, ICAESM-2012*, pp. 393-398, 30, 31 March 2012.
- Lee, K. and Z.Geem,"A new meta heuristic algorithm for continuous engineering optimization: Harmony Search theory and practice", *Comput. Methods Applied Mechanics Eng* 194:3902-3933, 2005.
- Muthukumar K., Dr.S.Jayalalitha, "Optimal Reactive Power Compensation by Shunt Capacitor Sizing Using Harmony Search Algorithm in Unbalanced Radial Distribution System for Power loss Minimization", *International journal of Electrical Engineering and informatics*, Volume 5 ,No: 4,PP 474-491, December 2013.
- Ramalinga Raju M., K.V.S. Ramachandra Murthy and K.Ravindra, "Direct search algorithm for capacitive compensation in radial distribution systems", *International journal of power & Energy Systems*, vol 42, PP 24-30, 2012
- Shirmohammadi D., H. W. Hong, A. Semlyen, and G. X. Luo, "A compensation-based power flow method for weakly meshed distribution and transmission networks," *IEEE Trans. Power Syst.*, vol. 3, pp.753- 762, May 1988.
- Sirjani R., A. Mohamed, H.Shareef, "Optimal capacitor placement in a radial distribution system using Harmony search algorithm", *Journal of applied sciences* 10(23), PP: 2998-3006, 2010.
- Teng, J. H., "Network-topology-based three-phase load flow for distribution systems", *Proc. Natl. Sci. Council. ROC (A)*, Vol.24, no.4, PP. 259-264, 2000.
- Thukaram, D., Wijekoon Banda, H. M. and Jerome, J., "A robust three phase power flow algorithm for radial Distribution systems," *Electric Power Systems Research*, vol.50, no.3, pp. 227-236, 1999.

Appendix- A

Table: A1. 119 –Bus Network Load Data

Bus	PL(KW)	QL(KVAr)	Bus.No	PL(KW)	QL(KVAr)	Bus.No	PL(KW)	QL(KVAr)
1	0	0	40	393.05	342.6	79	294.55	162.47
2	133.84	101.14	41	326.74	278.56	80	485.57	437.92
3	1	11.292	42	536.26	240.24	81	243.53	183.03
4	34.315	21.845	43	76.247	66.562	82	243.53	183.03
5	73.016	63.602	44	53.52	39.76	83	134.25	119.29
6	144.2	68.604	45	40.328	31.964	84	22.71	27.96
7	104.47	61.725	46	39.653	20.758	85	49.513	26.515
8	28.547	11.503	47	66.195	42.361	86	383.78	257.16
9	87.56	51.073	48	73.904	51.653	87	49.64	20.6
10	198.2	106.77	49	114.77	57.965	88	22.473	11.806
11	146.8	75.995	50	918.37	1205.1	89	62.93	42.96
12	26.04	18.687	51	210.3	146.66	90	30.67	34.93
13	52.1	23.22	52	66.68	56.608	91	62.53	66.79
14	141.9	117.5	53	42.207	40.184	92	114.57	81.748
15	21.87	28.79	54	433.74	283.41	93	81.292	66.526
16	33.37	26.45	55	62.1	26.86	94	31.733	15.96
17	32.43	25.23	56	92.46	88.38	95	33.32	60.48
18	20.234	11.906	57	85.188	55.436	96	531.28	224.85
19	156.94	78.523	58	345.3	332.4	97	507.03	367.42
20	546.29	351.4	59	22.5	16.83	98	26.39	11.7

.....Continue

93.167	54.594	61	95.86	90.758	100	100.66	47.572
85.18	39.65	62	62.92	47.7	101	456.48	350.3
168.1	95.178	63	478.8	463.74	102	522.56	449.29
125.11	150.22	64	120.94	52.006	103	408.43	168.46
16.03	24.62	65	139.11	100.34	104	141.48	134.25
26.03	24.62	66	391.78	193.5	105	104.43	66.024
594.56	522.62	67	27.741	26.713	106	96.793	83.647
120.62	59.117	68	52.814	25.257	107	493.92	419.34
102.38	99.554	69	66.89	38.713	108	225.38	135.88
513.4	318.5	70	467.5	395.14	109	509.21	387.21
475.25	456.14	71	594.85	239.74	110	188.5	173.46
151.43	136.79	72	132.5	84.363	111	918.03	898.55
205.38	83.302	73	52.699	22.482	112	305.08	215.37
131.6	93.082	74	869.79	614.775	113	54.38	40.97
448.4	369.79	75	31.349	29.817	114	211.14	192.9
440.52	321.64	76	192.39	122.43	115	67.009	53.336
112.54	55.134	77	65.75	45.37	116	162.07	90.321
53.963	38.998	78	238.15	223.22	117	48.785	29.156
					118	33.9	18.98

Table A2. 119 –Note Network Line Data

Bus Sec	From bus	To bus	R(Ω)	X(Ω)	Bus Sec	From bus	To bus	R(Ω)	X(Ω)	Bus Sec	From bus	To bus	R(Ω)	X(Ω)
1	1	2	0.036	0.01296	40	40	41	0.28	0.15	79	79	80	0.186	0.1227
2	2	3	0.033	0.01188	41	41	42	1.18	0.85	80	80	81	0.26	0.139
3	2	4	0.045	0.0162	42	42	43	0.42	0.2436	81	81	82	0.154	0.148
4	4	5	0.015	0.054	43	43	44	0.27	0.0972	82	82	83	0.23	0.128
5	5	6	0.015	0.054	44	44	45	0.339	0.1221	83	83	84	0.252	0.106
6	6	7	0.015	0.0125	45	45	46	0.27	0.1779	84	84	85	0.18	0.148
7	7	8	0.018	0.014	46	35	47	0.21	0.1383	85	79	86	0.16	0.182
8	8	9	0.021	0.063	47	47	48	0.12	0.0789	86	86	87	0.2	0.23
9	2	10	0.166	0.1344	48	48	49	0.15	0.0987	87	87	88	0.16	0.393
10	10	11	0.112	0.0789	49	49	50	0.15	0.0987	88	65	89	0.669	0.2412
11	11	12	0.187	0.313	50	50	51	0.24	0.1581	89	89	90	0.266	0.1227
12	12	13	0.142	0.1512	51	51	52	0.12	0.0789	90	90	91	0.266	0.1227
13	13	14	0.18	0.118	52	52	53	0.405	0.1458	91	91	92	0.266	0.1227
14	14	15	0.15	0.045	53	53	54	0.405	0.1458	92	92	93	0.266	0.1227
15	15	16	0.16	0.18	54	29	55	0.391	0.141	93	93	94	0.233	0.115
16	16	17	0.157	0.171	55	55	56	0.406	0.1461	94	94	95	0.496	0.138
17	11	18	0.218	0.285	56	56	57	0.406	0.1461	95	91	96	0.196	0.18
18	18	19	0.118	0.185	57	57	58	0.706	0.5461	96	96	97	0.196	0.18
19	19	20	0.16	0.196	58	58	59	0.338	0.1218	97	97	98	0.1866	0.122
20	20	21	0.12	0.189	59	59	60	0.338	0.1218	98	98	99	0.0746	0.318
21	21	22	0.12	0.0789	60	60	61	0.207	0.0747	99	1	100	0.0625	0.0265
22	22	23	1.41	0.723	61	61	62	0.247	0.8922	100	100	101	0.1501	0.234
23	23	24	0.293	0.1348	62	1	63	0.028	0.0418	101	101	102	0.1347	0.0888
24	24	25	0.133	0.104	63	63	64	0.117	0.2016	102	102	103	0.2307	0.1203
25	25	26	0.178	0.134	64	64	65	0.255	0.0918	103	103	104	0.447	0.1608
26	26	27	0.178	0.134	65	65	66	0.21	0.0759	104	104	105	0.1632	0.0588
27	4	28	0.015	0.0296	66	66	67	0.383	0.138	105	105	106	0.33	0.099
28	28	29	0.012	0.0276	67	67	68	0.504	0.3303	106	106	107	0.156	0.0561
29	29	30	0.12	0.2766	68	68	69	0.406	0.1461	107	107	108	0.3819	0.1374
30	30	31	0.21	0.243	69	69	70	0.962	0.761	108	108	109	0.1626	0.0585
31	31	32	0.12	0.054	70	70	71	0.165	0.06	109	109	110	0.3819	0.1374
32	32	33	0.178	0.234	71	71	72	0.303	0.1092	110	110	111	0.2445	0.0879
33	33	34	0.178	0.234	72	72	73	0.303	0.1092	111	109	112	0.2088	0.0753
34	34	35	0.154	0.162	73	73	74	0.206	0.144	112	112	113	0.2301	0.0828
35	30	36	0.187	0.261	74	74	75	0.233	0.084	113	100	114	0.6102	0.2196
36	36	37	0.133	0.099	75	75	76	0.591	0.1773	114	114	115	0.1866	0.127
37	29	38	0.33	0.194	76	76	77	0.126	0.0453	115	115	116	0.3732	0.246
38	38	39	0.31	0.194	77	64	78	0.559	0.3687	116	116	117	0.405	0.367
39	39	40	0.13	0.194	78	78	79	0.186	0.1227	117	117	118	0.489	0.438
